

Pakistan Telecommunication Company Limited

Regional Procurement, Karachi.

No.1-42/2020/RPC/KHI/TENDER/Shore

Dated: 7th October, 2020

Tender for Protection of SMW3 and IMEWE Submarine Cables at Hawksbay Beach, Karachi.

Sealed Bids are invited from Vendors registered with PTCL for “**Tender for Protection of SMW3 and IMEWE Submarine Cables at Hawksbay Beach, Karachi.**”

Tender documents may be obtained online from PTCL Tender Page from 8th Oct, 2020 to 15th Oct 2020.

1. Tender document available on website should be complete in all respects Technical and Commercial and should be dropped in bid box on or before **16th Oct, 2020** at Regional Procurement Office, EVP Zonal Office, Hatim Alvi Road, Clifton Block-4, Karachi along with the payment of Rs 1000 (Non Refundable) as per instructions to the bidders contained in the Bid Documents
2. One Sealed envelope shall contain the **Technical Offer** and Second sealed envelope shall contain the **Commercial Offer**.
3. Bid Security 2% of total tender value should be put in a separate envelop along with Commercial Offer in the shape of Pay order in favor of “Senior Manager Finance, Business Zone South Karachi”, and undertaking confirming the same must be part of Technical Bids. **In case of non-compliance, the bids will be disqualified from further processing.**
4. Bids without security money will be rejected.
5. Bids received after the deadline shall not be accepted.
6. PTCL reserves the right to reject any or all bids and to annul the bidding process at any time, without thereby incurring any liability to the affected bidder (s) or any obligations to inform the affected bidder (s) of the grounds for PTCL Action.
7. The contractors registered with PTCL for this particular category would be eligible to participate in the tender. Bidder must mention their Vendor Registration code on quotation. In case vendor is not registered, then registration must be done before the issuance of Letter of Intent (LOI). Vendor Registration form can be downloaded from PTCL website <http://www.ptcl.com.pk/>
8. All correspondence on the subject may be addressed to the undersigned.

**Manager Regional Procurement
021-35810038**

PAKISTAN TELECOMMUNICATION COMPANY LIMITED

SENIOR MANAGER REGIONAL PROCUREMENT SOUTH KARACHI



RFQ No. 1-42/2020/RPC/KHI/TENDER/Shore

**REQUEST FOR QUOTATION
(RFQ)**

FOR

**“Tender for Protection of SMW3 and IMEWE Submarine Cables at Hawksbay Beach,
Karachi.”**

INSTRUCTIONS TO THE BIDDER

A. OFFER SUBMISSION

SEALED OFFER

Bidders participating in tender are requested to make two separate submissions in separate sealed envelopes.

- **Technical Offer.**

One sealed envelope shall contain the technical offer (un-priced bid) along with the specification and all other technical details. This envelope should be clearly marked as "TECHNICAL OFFER".

- **Commercial Offer**

Second sealed envelope shall contain the commercial offer (price bid) with the cost breakdown as per the Company price schedule / bill of quantity (BOQ). This envelope shall be marked as "COMMERCIAL OFFER".

Both of the above mentioned sealed envelopes must bear PTCL's request for proposal (RFP)/ request for quotation (RFQ) reference number. No other details such as name of tenderer or any other reference shall be mentioned on these envelopes.

The sealed offer is to be deposited in the relevant tender box located at EVP Zonal Office Clifton in Procurement Department of PTCL or any other designated office mentioned in the tender documents.

- **Tender Opening.**

The bidders shall not be allowed to attend any Tender Opening Committee meetings. TOC meetings shall be conducted in strict confidence by the PTCL committee members and thus must not be revealed to any external party of any kind whatsoever.

B. DOCUMENTS TO BE SUBMITTED WITH TECHNICAL PROPOSAL

The bid shall comprise following documents

1. Company profile, background
2. Registered Offices and contacts in Pakistan.
3. Management, Staff Strength & operational vehicles.
4. Details of tools, machinery & equipment's.
5. Certificate of Pakistan engineering council.
6. Areas of Specialization
7. Experience in relevant Projects or the relevant fields
8. Technical Platforms at its disposal
9. Other Projects
10. References
11. Compliance with all the clauses of technical specifications
12. Compliance with all the clauses of bidding terms and conditions.

13. Compliance with all the clauses of implementation plan in the form of certificate
14. Compliance with the system requirements, in particular, performance of the solution offered in the form of certificate.
15. Technical solution offered with comprehensive detail supported by printed literature/ brochures/ user manuals etc.
16. Certificate confirming that bidder has placed original bid bond in the form of bank guarantee as per requirement of PTCL in the commercial bid. **Technical Bids without such certificates are liable to be rejected.** This certificate should not bear the amount of bank guarantee or the bid value
17. Each page of technical proposal must be signed and stamped by the bidder.

C. DOCUMENTS TO BE SUBMITTED WITH COMMERCIAL BID

The bid shall comprise following documents

1. Bid Bond of required Amount.
2. Signed and stamped Commercial Compliance Sheet.
3. Duly filled and signed Bid Form.
4. Sales Tax Registration Certificate (for local bidders).
5. Tax return for last 3 years.
6. NTN Certificate (for local bidder).
7. Prices on PTCL Format (Duly Signed & Stamped).
8. Certificate on stamp paper that the bidder is not black listed by any company or Government Organization.

D. Dead Line for Submission of Bids

Bids shall be dropped in the Tender Box available at Office of the Senior Manager Procurement Karachi at addressed PTCL EVP Zonal Office Clifton on or before 3rd Oct 2020 from 10:00 to 14:00 hrs.

PTCL may its discretion, extend this deadline for the submission of bids by amending the bidding documents, in which case all rights and obligations of PTCL and Bidders previously subject to the deadline will thereafter be subject to the deadline as extended.

E. Submission of Bids

- a. The Bidders shall seal both Technical & Commercial bids in two separate Envelopes marking Technical & Commercial Bids, enclosed in third Envelop.
- b. The envelope shall be addressed to PTCL at the following address:

**The Senior Manager Regional Procurement South,
Basement EVP South Zonal Office, Hatim Alvi Road,
Block-4, Clifton, Karachi
Phone: 92-21-35373120**

- c. Bear the RFP/RFQ number and the words "DO NOT OPEN BEFORE 16-10-2020.
- d. The inner envelope shall indicate the name and address of the Bidder to enable the bid to be returned un-opened in case it is decided '**Late**'.
- e. The bidders shall submit their Commercial proposals (Priced Bid) in separate sealed envelopes with the cost breakdown as per PTCL price schedule/BOQ, ensuring that this envelope must be marked as "Commercial Offer". Sealed envelopes must bear PTCL tender reference number without any other details or name of tenderer or any other reference.

F. Modification and Withdrawal

- 1.1 The Bidder may modify or withdraw his bid after the bid's submission, provided that written notice of the modification or withdrawals is received by PTCL prior to the deadline prescribed for submission of bids.
- 1.2 The Bidder's modification or withdrawal notice shall be prepared, sealed, marked and dispatched in accordance with the provisions of clauses of this RFT. A withdrawal notice may also be sent by fax but followed by a signed confirmation copy by post marked and received not later than the deadline for submission of bids.
- 1.3 No bid may be modified subsequent to the deadline for submission of bids.
- 1.4 No bid may be withdrawn in the interval between the deadline for submission of bids and the expiration of the period of bid validity specified by the Bidder on the Bid Form. Withdrawal of a bid during this interval may result in the bidder's forfeiture of its bid security.

G. Clarification of Documents

A prospective bidder requiring any clarification of Bidding Documents may notify the PTCL in writing at PTCL's mailing address indicated in the Invitation for Bid. PTCL will respond in writing to any request for clarification of the Bidding Documents which it receives not later than (Five) 5 days prior to the deadline for the submission of bids prescribed by PTCL. Written copies of PTCL's response to common queries (including an explanation of the query but without identifying the source of the inquiry) shall be sent to prospective bidders, which have received the Bidding Documents. Response to all such queries from the PTCL shall be about two 02 days before the closing date.

H. Amendment in Documents

1. At any time prior to the deadline for submission of bids, PTCL may, for any reason, whether on its own initiative or in response to a clarification requested by a prospective Bidder, modify the provisions of Bidding Documents by circulation of formal letter of amendment to all those parties who have purchased the Bidding Documents.
2. The amendment shall be notified in writing to all prospective Bidders who have received the Bidding Documents and will be binding on them.

I. Format and Signing of Bid

1. The Bids shall be typed or written in indelible ink and shall be signed by the Bidder or person or persons duly authorized to bind the Bidder to the Tender/Contract. The letter of authorization shall be indicated by written 'Power-of-Attorney' accompanying the bid. All pages of the bid, except for un-amended printed literature shall be initialed by the person or persons signing the bid. Price schedule should be properly signed and stamped particularly. If the price schedule is not signed and stamped the bid will be treated as non-responsive and rejected.
2. The bid shall contain no interlineations, erasures or overwriting except as necessary to correct errors made by the Bidder in which case such correction shall be initialed by the person or persons signing the bid otherwise, the bid will be treated as non-responsive and rejected.

J. REJECTED GOODS/SERVICES/WORK

Damaged or wrongly supplied/services/work or Poor quality Goods/Services/Work shall be rejected and replaced by supplier/vendor without any additional cost to PTCL.

TECHNICAL OFFER

“Tender for Protection of SMW3 and IMEWE Submarine Cables at Hawksbay Beach, Karachi”

1- Scope:

In order to ensure effective protection of PTCL SMW3 and IMEWE Submarine Cables against harmful impact during exposure at landing point Hut A-14 Hawksbay, Articulated Pipe protection is required as per international standards.

Scope of work is detailed as below:

1. Tracking of shore end cable alignment from the Beach Manhole / External Boundary Wall to low level water mark at beach/inside sea.
2. Excavation / exposure of cable & lowering the cable up to permissible depth by excavator / manual labour.
3. Fixing & Installation of bulkhead split Flange at SMW-3 Cable entry at external boundary wall as per international standard /given procedure.
4. Fixing & Installation of Ductile Cast Iron Articulated Pipes (ISO 1083) as per international standards / given procedure.
5. Lowering the cable to a permissible depth taking all precautionary measures to secure the live cables from any damage.
6. Fixing & Installation of CC bags over the articulated fitted cable portion.
7. Back filling & reinstatement of excavated soil.

2- **BoQ:**

S#	DESCRIPTION OF ITEM / WORK	Type (If Any)	Unit	Qty
1	SG/Ductile Cost Iron Articulated Pipes with complete accessories required for fixing of complete length.	As mentioned in the Tech Specification part	Meters	200
2	Supply of Bulk head split	As mentioned in the Tech Specification part	Each	01
3	Supply 1.5' X 2' CC bags 1:1 ratio cement & sand 50 Kg weight .		Each	400
4	Excavation at Shore End side. Exposure & lowering the cable up to permissible depth by Excavator / Manual labor including backfilling after completion of job.		Meters	200
5	Fixing & installation of Ductile Iron Articulated Pipes as per international standard		Meters	200
6	Fixing & installation of Bulk head split Flange as per international standard		Each	01
7	Fixing & installation of cc bags		Meters	200

3- Technical Specifications:

A. Articulated Pipes

Spheroidal Graphite (SG) Cast Iron a high-quality alloy providing a high level of resistance to impact, fatigue and corrosion (also known as Nodular and Ductile). SG cast Iron split-pipe manufactured in accordance with International Standard ISO 1083 and widely used for the physical protection of submarine cables at beach or inside sea. Designed for each section (or piece, or half) to connect and interlock by hook and pin arrangement and articulate by ball and socket connection, each pair resulting in half meter installed length for ease of handling and installation.

Main Features:

Material	SG/Ductile Cost Iron
Manufacturing standard	ISO 1083
Installed Length minimum	495 mm
Installed Length maximum	510 mm
Nominal wall Thickness	9 mm
Weight in Air	17.6 kg/m
Minimum Internal Diameter	55 mm
Assembled minimum bend radius	2 m
Tensile Strength	400 Mpa
Minimum elongation	15%
Impact Resistance	Greater than 3500 joule IS

Assembly and Fixings:

Each piece (i.e. section or half) of each pair to be identical and interchangeable with others. Either side of each piece adjacent to either side of the socket webs plates shall be formed to accommodate a pair of locating dowels/pegs ether side to limit lateral movement and similarly a pair of A4 Stainless Steel (316 grade) Hexagonal M12 x 50mm fixing sets (typically Hexagon full nut and bolt, two flat form A and one spring/split/coil washer). The fixing webs shall each not exceed maximum 16mm and minimum 10mm in thickness. Mating surfaces free of flash and flat with maximum bowing or arching of 1mm permissible.

Casting and ID:

Finish shall be “as-cast” and free of significant surface defects; pitting not to exceed depth 1.5mm, length 30mm; Shrinkage porosity must not be excessive. Each piece (i.e. section or half) to have an ID cast on the external or internal face that uniquely and directly correlates with the material certification raised for that casting batch/melt for traceability. The ID shall be alpha-numeric characters minimum 5mm high and 1mm proud of the main casting.

Mechanical Acceptance Testing and Certification:

The product must pass the prescribed design and manufacture integrity test and test detailed should be provided with the product.

B. Bulhead Split flange

Bulkhead split flange for terminating any pipe with shaft diameter of up to 75 mm to a flat surface such as a Beach Manhole (BMH) or wall .

Requires bolting together with four A4 (316 grade) Stainless Steel M12 x 50mm bolts with washers and nuts
Secure Bulkhead Split Flange to concrete wall with 6 x M12 concrete fixings

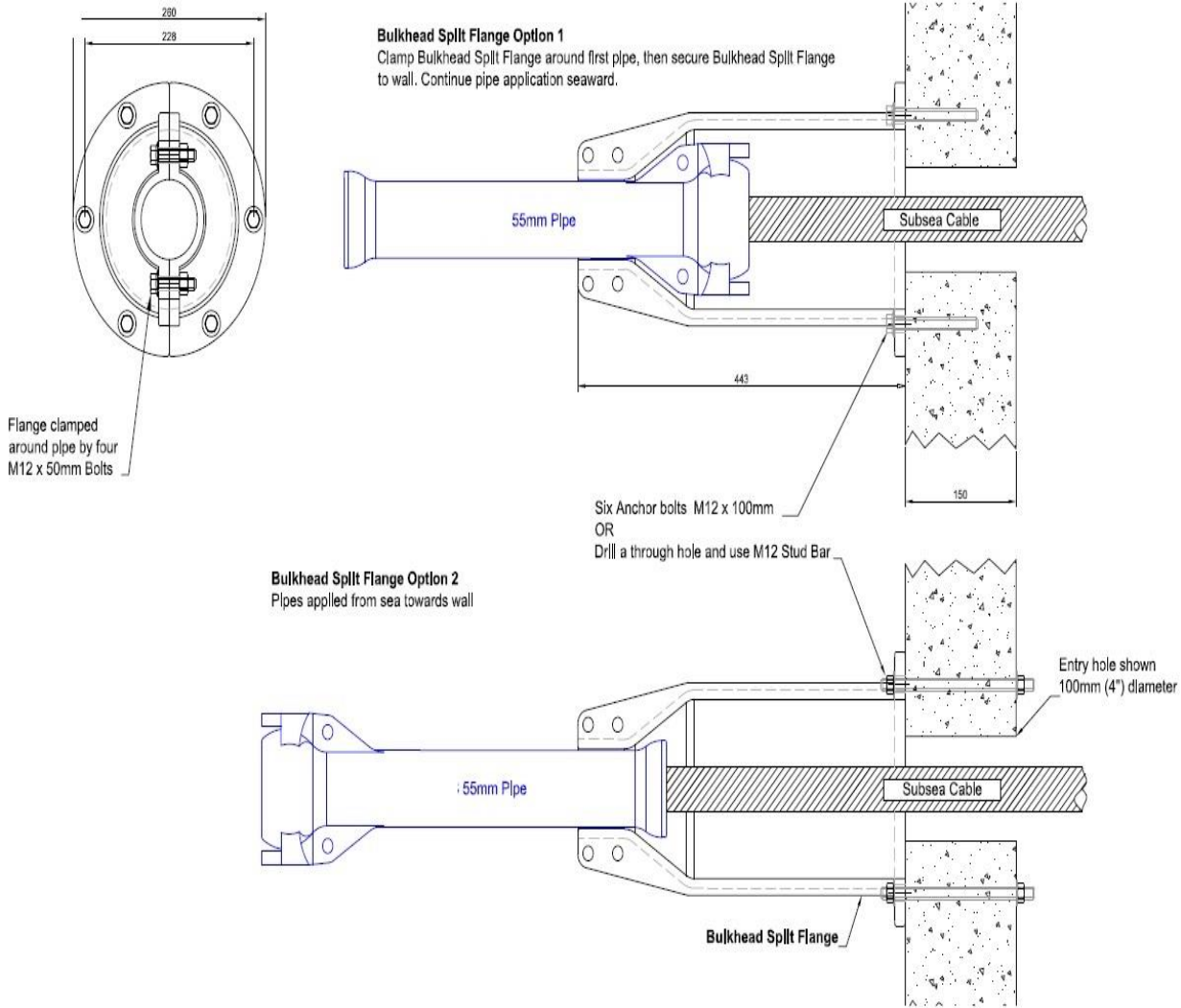

3. Technical Strengths of the Bidder:

The Bidders will be provide the following information related to his Technical Strengths in his Technical Proposal

TECHNICAL STRENGTHS & BACKGROUND

QUERIES REGARDING TECHNICAL STRENGTH		
1	Experience in no. of Years for Providing Services.	
2	No. of Work Orders issued by PTCL in last One Year (> PKR 1 Million) in similar Category	
3	No. of Work Orders issued by other Organizations in last One Year (> PKR 1 Million) in similar Category	

5. PTCL Reserves the rights

- 6.1 PTCL reserves the rights to make changes in the specification at any time without any notice.
- 6.2 PTCL cannot guarantee that any of the requirements, standards, regulations, and conditions of this specification are not covered or protected by copyright or patent of a third party.

1. *Clause by clause compliance statement*

The bidder shall furnish a clause by clause compliance for each clause/sub-clause of this specification. The Bidder shall provide technical description in detail for each compliance statement. The clauses which need description/figures must be provided otherwise bid will be considered non-compliant.

- a. **“Fully compliant”**, If items offered fully meet the tender requirement.
- b. **“Partially compliant”**, if the offered items and their functions meet the tender requirement partially, the bidder shall state the reason for partially compliant. However, if the bidder is able to fulfill the specified requirement later on, the time schedule be mentioned in the offer.
- c. **“Non-compliant”**, if the offered items and their functions not meet the requirements, the bidder shall state the reason for it.
- d. In case of unclear statement of compliance for any specified requirement, PTCL will interpret that particular requirement as **“Non-Compliant”**.
- e. For every clause, the Bidder must mention in the same table the reference of document (document name/number and page number) where evidence has been provided in support of the clause.
- f. The bidder must submit soft (CD’s / Flash memory disc) and hard copy of Compliance statement of each clause/sub clause of technical specifications as in the given format.

Clause/Sub clause #	Compliance statement (C/PC/NC)*	Reference (Document & Page #)	Remarks (if any)

- * C for Complaint
- PC for Partially Compliant
- NC for Not Compliant

TECHNICAL COMPLIANCE STATEMENT

S.#	CLAUSE OF STATEMENT	COMPLIANCE	REMARKS
1	Scope		
2	Technical Specifications		
3	BOQ Manageable		
4	Technical Strengths sheet filled		

NAME OF BIDDER & STAMP OF COMPANY

COMMERCIAL OFFER

“Tender For Protection of SMW3 and IMEWE Submarine Cables at Hawksbay Beach, Karachi”

I/We hereby certify and confirm that while quoting above rates for providing above noted job/supplies/services/work. I have carefully read the tender specification, B.O.Q. general and detailed terms and conditions of the tender document and other details. In confirmation thereof, I put my Signature and Seal on this Tender Bid as under on this day of _____.

Protection of SMW3 and IMEWE Submarine Cables at Hawksbay Beach						
S#	DESCRIPTION OF ITEM / WORK	Type (If Any)	Unit	Rates	QTY	Amount
1	SG/Ductile Cast Iron Articulated Pipes with complete accessories required for fixing of complete length.	As mentioned in the Tech Specification part	Meters		200	
2	Supply of Bulk head split	As mentioned in the Tech Specification part	Each		1	
3	Supply 1.5' X 2' CC bags 1:1 ratio cement & sand 50 Kg weight .		Each		400	
4	Excavation at Shore End side. Exposure & lowering the cable up to permissible depth by Excavator / Manual labor including backfilling after completion of job.		Meters		200	
5	Fixing & installation of Ductile Iron Articulated Pipes as per international standard		Meters		200	
6	Fixing & installation of Bulk head split Flange as per international standard		Each		1	
7	Fixing & installation of cc bags		Meters		200	

Signature of the Contractor with Name of Company & Stamp: _____

COMMERCIAL COMPLIANCE STATEMENT

S.#	CLAUSE OF STATEMENT	COMPLIANCE	REMARKS
	DOCUMENTS TO BE SUBMITTED WITH COMMERCIAL BID Commercial Compliance Part		
1	Bid Bond of Required Amount		
2	Signed and Stamped Commercial Compliance Sheet		
3	Duly Filled and Signed Bid Form		
4	Sales Tax Registration Certificate		
5	Tax Return for last 3 years		
6	NTN Certificate		
7	Rates on PTCL Format		
8	Certificate on Stamp paper that the Bidder is not Black listed by any company or Govt. organization		

A. Contractor's Negligence

The Contractor shall indemnify PTCL in respect of all injury or damage to any person or to any property and against all actions, suits, claims, demands, charges and expenses arising in connection herewith which shall be occasioned by the negligence or breach of statutory duty of the Contractor, any sub-Contractor before or after, the whole of the project has been finally accepted.

i. Delays In Performance

Any un-justifiable delay by the Contractor in performance of its services/delivery/project completion obligations shall render the Contractor liable to any or all penalties, charges of the goods and performance of services/work, the Contractor shall promptly notify PTCL In writing of the fact of the delay, its likely duration and its causes. As seen as practicable after receipt of the Contractor's notice, RGM KTR-1,2 & 3 (Operation) shall evaluate the situation and may at its discretion extend the Contractor time for performance in which case time extension shall be ratified by the parties by amendment of the Contract.

ii. Contractor's Default

If the Contractor shall neglect to perform the Contract with due diligence and expedition or shall refuse/or neglect to comply with any reasonable orders given to him in writing by PTCL or any of its authorized representative in connection with the performance of the Contract or shall contravene the provisions of the Contract, PTCL may give notice In writing to the Contractor to make good the failure, neglect or contravention complained of.

iii. Should the Contractor fail to comply with the said notice, within a period of fifteen (15) days from the date of services/work thereof, it shall be lawful for PTCL forthwith to terminate the Contract by notice in writing to time Contractor without prejudice to any rights which may have accrued under the Contract to either party prior to such termination.

iv. Amicable Settlement

- v. The Contract will be construed under and governed by THE LAWS OF THE ISLAMIC REPUBLIC OF PAKISTAN.
- vi. PTCL and the Contractor shall make every effort to resolve amicably by direct informal negotiation any disagreement or dispute arising between them under or in connection with the Contract.
- vii. Except as otherwise provided in the Contract, any difference, dispute or question arising out of or with reference to the Contract which cannot be settled amicably shall within (30) thirty days from the date that either party informs the other in writing that such difference, dispute or question exists be referred to arbitration.
- viii. Within 30 (thirty) days of the said notice, both parties shall nominate and agree upon a sole arbitrator for commencement of the arbitration proceedings.
- ix. The arbitration shall be conducted in accordance with the rules of procedure set forth in the Pakistan Arbitration Act 1940 (as amended). The arbitration Tribunal shall have its seat in Karachi, Pakistan.
- x. The award of the arbitrator shall be final and binding on both parties. The cost of the arbitrator shall be borne equally by both parties.
- xi. In the event of an arbitrator resigning or becoming incapable or unable to act, the parties shall nominate and agree on a replacement within two weeks of such an event. Proceeding shall continue without recommencing as if such arbitrator had been originally nominated.

B. FORCE MAJEURE



- i. Notwithstanding the provisions of the clauses of this RFT, the Contractor shall not be liable for forfeiture of its performance security, liquidated damage or termination for default, if and to the extent that, It's delay in performance or other failure to perform its obligations under the Contract is the result of an event of Force Majeure.
- ii. The terms "Force Majeure" as used herein shall mean Acts of God, strikes, lockouts or other Industrial disturbance, act of public enemy, war, blockages, insurrections, riots, epidemics/pandemic, landslides, earthquakes, fires, storms, lightning, flood, washout,, civil disturbances, explosion, Governmental Export/Import Restrictions (to be supported by a loner from the relevant Authority and verified by the Diplomatic Mission in Pakistan), Government actions/restrictions due to economic and financial hardships, change of priorities and any other cause similar to the lied herein enumerated or of equivalent effect, not within the control of either party and which by the exercise of due care and diligence either party is unable to overcome. The term of this Contract shall be extended for such period of time as may be necessary to complete the work which might have been accomplished but for such suspension. If either party is permanently prevented wholly or in part by Force Majeure for period exceeding ONE (01) month from performing or accepting performance, the party concerned shall have the right to terminate this Contract immediately giving notice with all particulars for such Force Majeure in writing to the other party, and In such event, the other party shall be entitled to compensation for an amount to be fixed by negotiations and mutual agreement.
- iii. If a Force Majeure situation arises, the Contractor shall promptly notify PTCL in writing of such conditions and the cause thereof. Unless otherwise directed by PTCL in writing, the Contractor shall continue to perform its obligations under the Contract as far as is reasonably practicable, and shall seek all reasonable alternative means for performance not prevented by the Force Majeure event.

C. TERMINATION OF CONTRACT

C.1.1 Termination of Contract for Default

- C.1.2 PTCL may, without prejudice to any other remedy for breach of Contract, by written notice sent to the Contractor to terminate this Contract in whole or in part.
- C.1.3 If the Contractor fails to render its supplies/services/work as specified in this Contract or any extension thereof granted by PTCL if the Contractor fails to perform any other obligation under the Contract.
- C.1.4 If the Contractor, in either of the above circumstances, does not cure its failure within a period of Ten (10) days (or such longer period as PTCL may authorize in writing) after receipt of the default notice from PTCL.
- C.1.5 In the event PTCL terminates the Contract in whole or in part, PTCL may procure, upon such terms and in such manner as it deems appropriate, goods and services/works similar to those Un-delivered, and the Contractor shall be liable to PTCL for any excess costs for such same similar goods and services/works. However, the Contractor shall continue, performance of the Contract to the extent not terminated.

D. Termination for Insolvency



- D1.1 With out prejudice or affecting of any right action or remedy which has accrued or will accrue there-after to PTCL, PTCL may at any time terminate the Contract by giving written notice to the Contractor, without compensation to the Contractor if the Contractor becomes bankrupt or otherwise insolvent (this includes voluntary as well as involuntary winding up of the Contractor/Company).
- D1.2 In the case of voluntary winding up of the contractor for the purpose of reconstruction or amalgamation, or if the contractor carries on its business under a receiver for the benefit of its creditors, or any of them PTCL shall be at liberty;
- a) To terminate the contract forthwith by notice in writing to the contractor or to the receiver or liquidator or to any person in whom the contract may become vested, in which event the relevant portion of paragraph titled "**TERMINATION FOR DEFAULT**" shall apply as if the contract had been terminated in pursuance thereof; or
 - a) Give such receiver, liquidator, or other person the option of carrying out the contract subject to his providing a guarantee for the due and faithful performance of the contract up to an amount to be agreed.

E. Termination For Convenience

- i) PTCL may by written notice sent to the Contractor terminate the Contract in whole or in part at any time for its convenience. The notice of termination shall specify that termination is for PTCL convenience, the extent to which performance of work under the Contract is terminated, and the date upon which such termination becomes effective.
- ii) The goods/services/work which are to be rendered / delivered within 15 days after the Contractor's receipt of notice of termination shall be purchased by PTCL at the Contract terms and prices. For the remaining goods/services/work, PTCL may select;
 - a) To have any portion completed and delivered at the Contract terms and prices; and/ or,
 - b) To cancel the remainder and pay to the Contractor an amount equal to 05% of the contract price of the remainder. Alternatively the Contractor may be reimbursed for any expenses incurred for partially completed goods and material and parts already ordered.

F. EFFECTIVE DATE OF CONTRACT

The Contract shall come into force from the date of issuance of Letter of Award (LoA).

	(CLAUSE / SUB-CLAUSE)	COMPLIANCE	REMARKS
	1	2	3

The Compliance Sheet is meant for stating the tender's compliance / non-compliance on all clauses and it is divided into three columns. The bidder shall complete the Compliance Sheets strictly in accordance with the instructions given below:

Column-1 :	For specifying the clause number to which the information in column 2 and 3 applies.
Column-2 :	For stating whether the tender's offered terms and conditions conforms to the clause in column-1 by using one of the following symbols.
A) :	The tender's offered terms and condition fully conforms to the clause in column-1.
B) :	The tender's offered terms and conditions do not fully conform to the clause in column-1.
Column-3 :	State the alternative only if the Symbol B has been used in Column-2. The benefit which PTCL will have if such alternative is accepted must be stated.

The bidder shall complete the Commercial Compliance Sheet furnished in the Bid Documents strictly in accordance with the instructions. However the following points are further added.

1. A word such as "noted" is inadequate and will be treated as not complied.
2. Where a clause is stated to be "complied" the bidder may provide further reference details, but in event of any discrepancy between these details and the statement of compliance, then the compliance statement will be taken by the PTCL as correct and binding upon the bidder and the details (including footnotes or specified in any other form or place) given by the bidder will be ignored
3. Where the clause is stated to be "not complied" or "partially complied" then the bidder will provide full details of the deviation from the specified requirements together with full details of any alternative arrangement offered.
4. Simply signing of every page of bid documents will not serve the purpose of the compliance statement and will be treated as not complied. Therefore, proper compliance sheet should be attached with the bid.
5. If a certain clause(s)/sub-clause(s) are missed or left unattended in commercial compliance sheet such clause(s) or sub-clauses would be considered as not complied.
6. Failure to provide commercial compliance will be deemed sufficient cause of rejection of the bid and will be major deviation.